

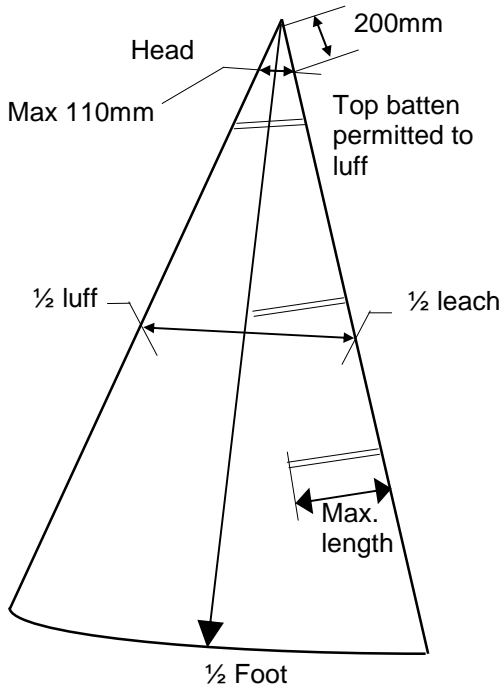



# JIB

## Sails :- Rules 14.1 to 14.7 and 15.1 to 15.17



Luff Max	4120	
Leech Max	3820	
Foot Max	1690	
1/2 Leech to 1/2 Luff	850	
Head to mid point of foot max	3965	
200mm down leech to nearest luff	110	
Max number of battens	3	
Max length of battens	300	

# MAINSAIL

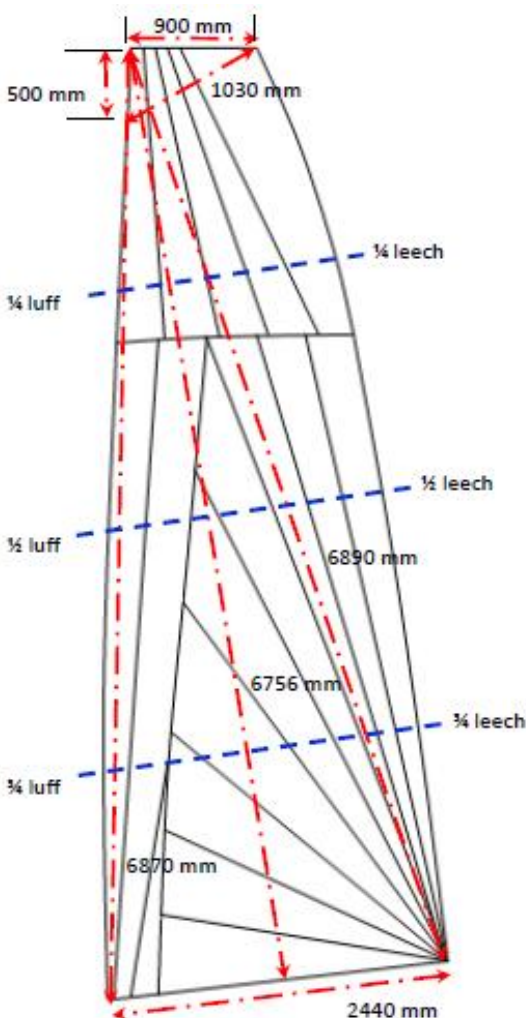

Max Head to mid point of foot	6756	
Max length of Luff	6870	
Max length of Leech	6890	
Max length of Foot	2440	
1/4 Luff to 1/4 Leech	1610	
1/2 Luff to 1/2 Leech	2050	
3/4 Luff to 3/4 Leech	2330	
500mm down on Luff to corner of head	1030	
Head shape 90° to the luff		
Max length of head	900	
Max number of battens (8) + 1 foot	9	
Max width of battens	55	
Max projection of battens from Leech	100	

Existing sails will continue to be recognised and will be legal in all regattas. New sails made after 8<sup>th</sup> September 2013 will be required to be made to the new rule

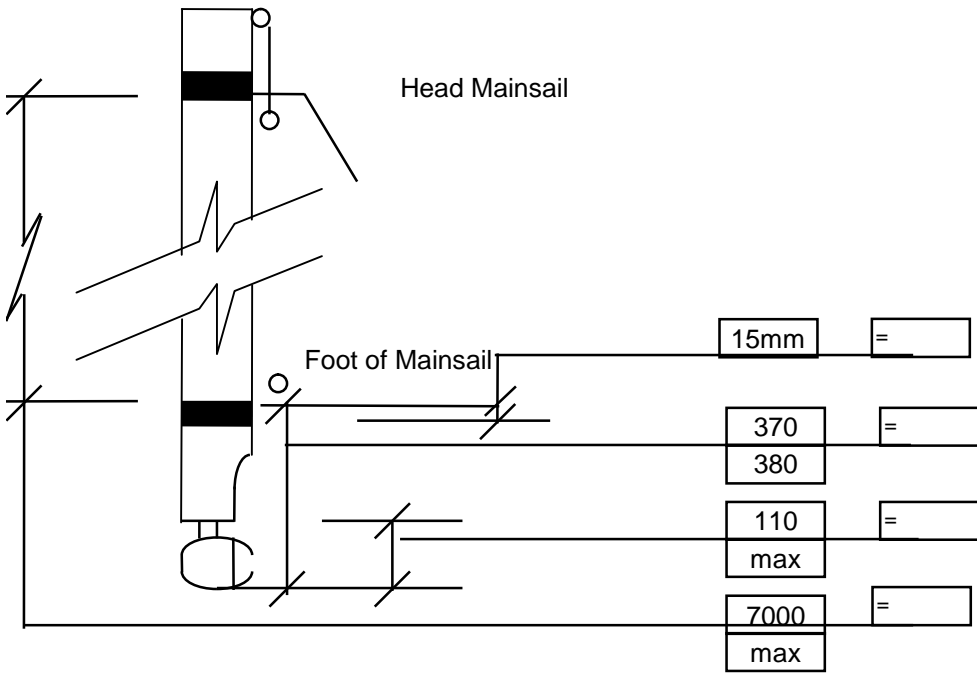

Boom Rules 10.1 to 10.3

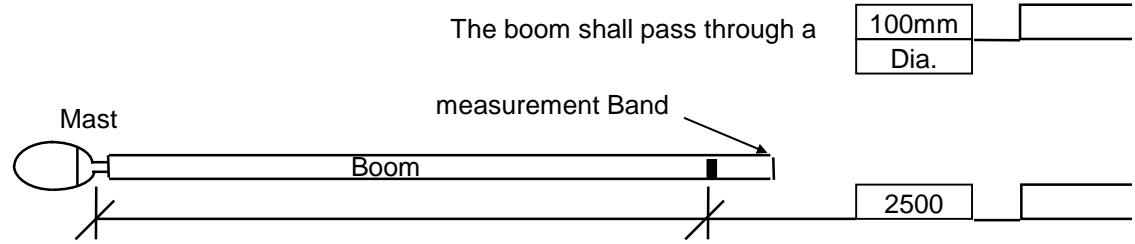

Standard Rigging. Rule 12.1

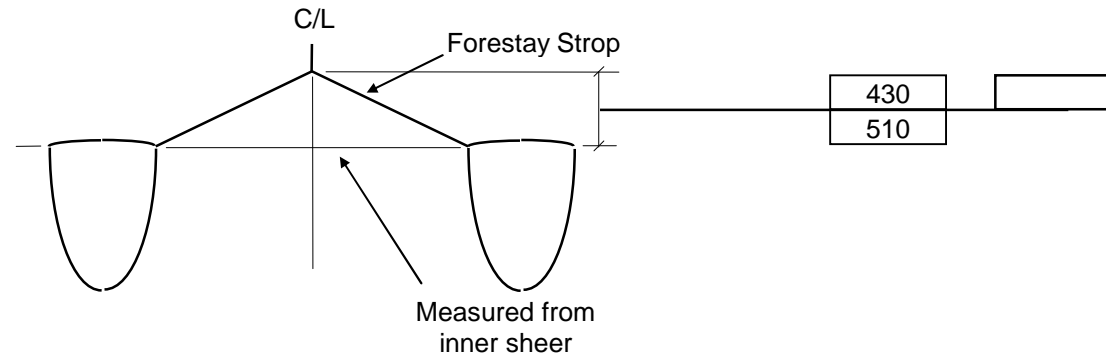
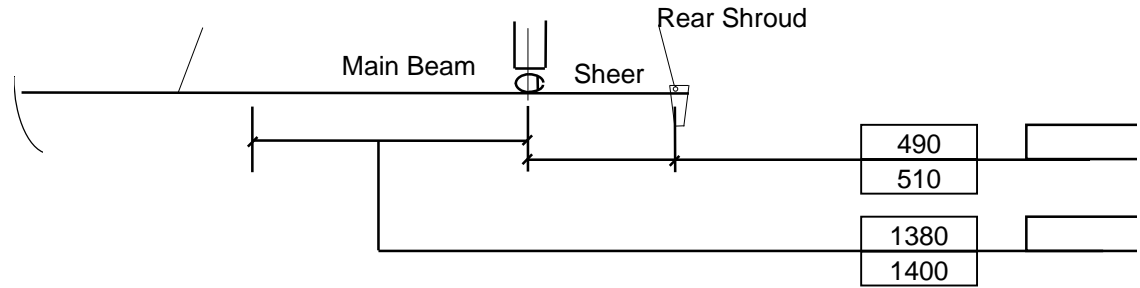

Rigging 2.1 to 12.8

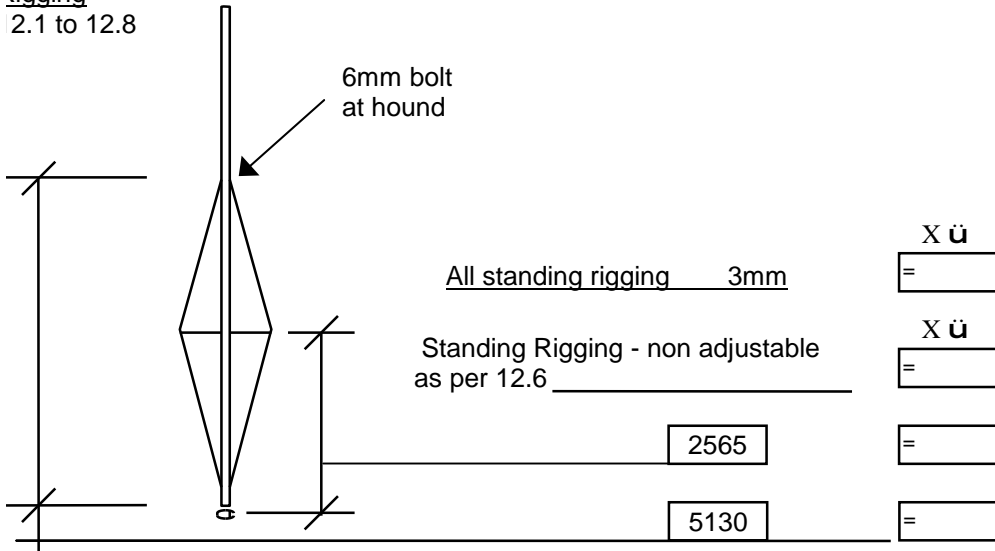

Beams - 4.1 to 4.11

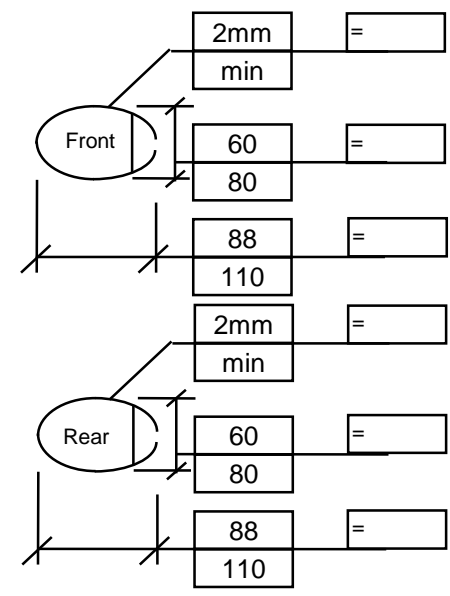
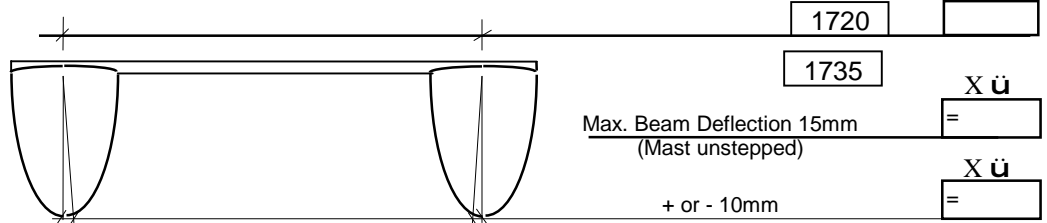
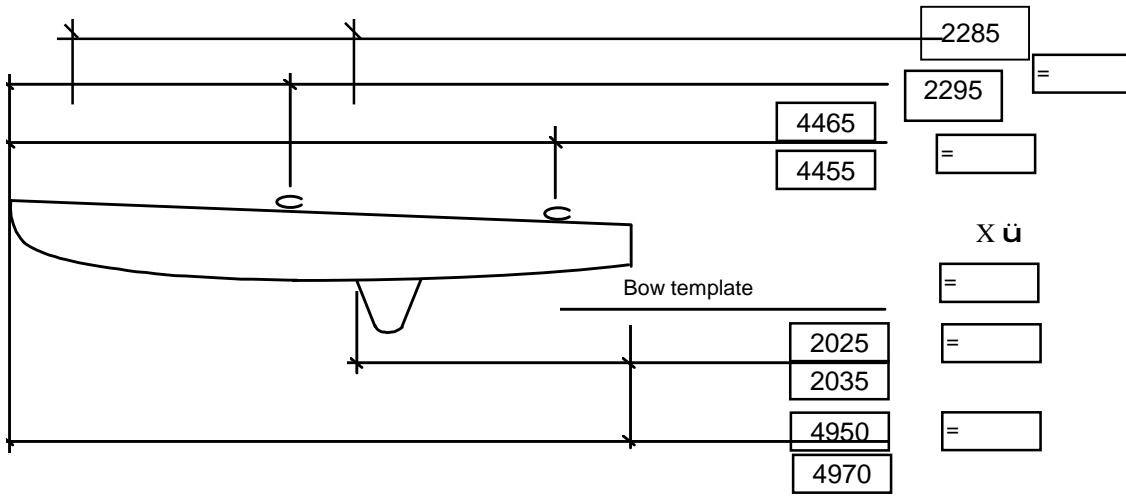

Beams parallel to Shear =

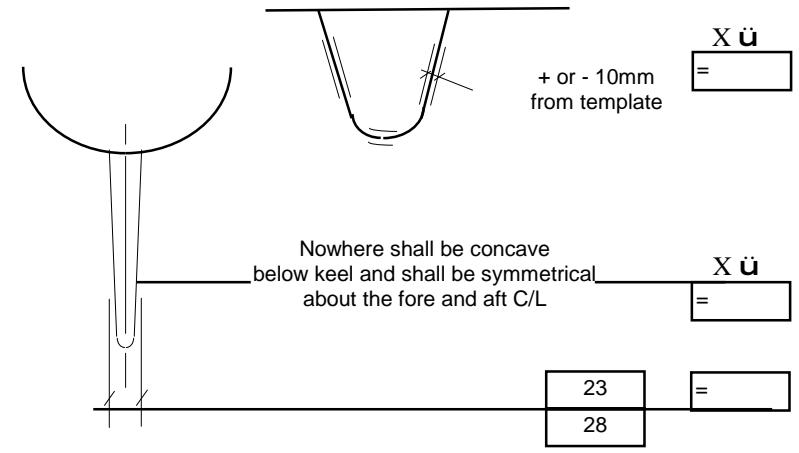

Rudders Rule 7.1 Must be attached so as to retain them in the event of a capsize.

Weight of hulls etc. Rules 8.1 to 8.5

- Dry hulls.
- Beams and Tramp.
- Main Traveller and Track.
- Centreboards.
- All permanent fixtures bolted, screwed or otherwise permanently fixed to boat.
- Weight corrector located in Main Beam

Min Weight 77 Kg